

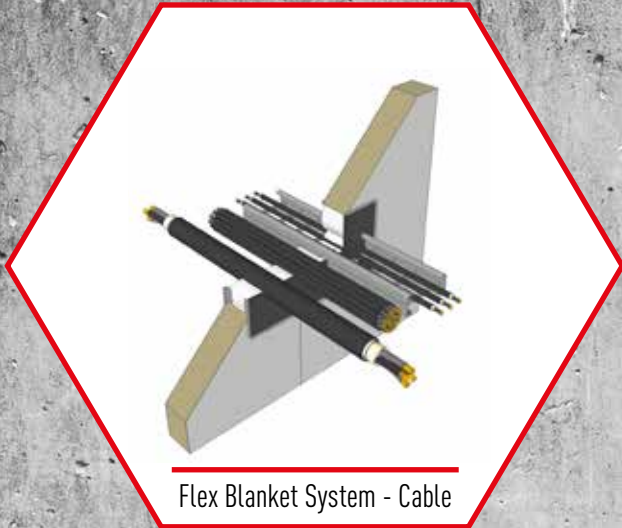

FireSeal

FIRESEALING IN SANDWICH PANELS



Flex Blanket System - Cable

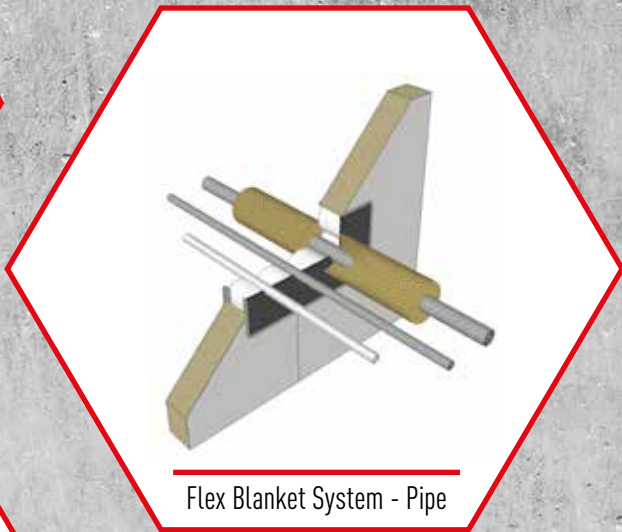

Flex Blanket System - Pipe

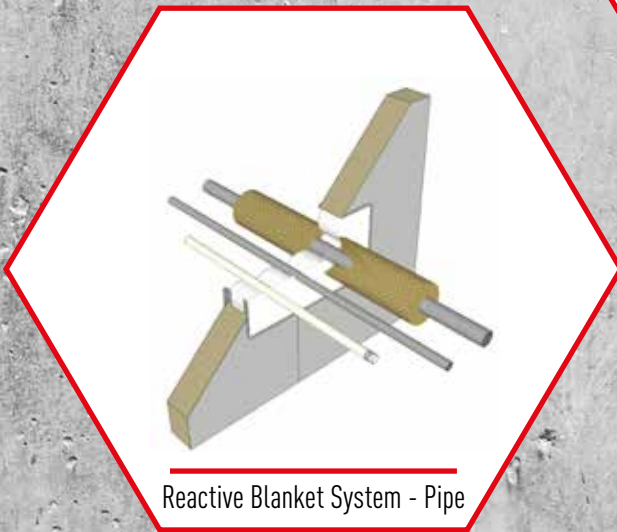

Reactive Blanket System - Pipe

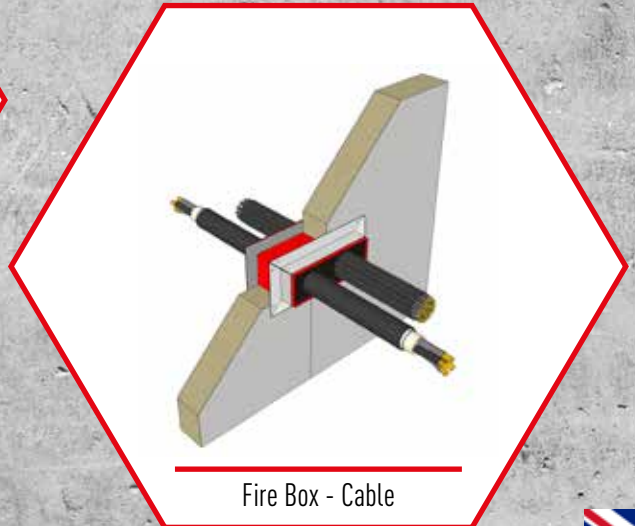

Fire Box - Cable



INTRODUCTION

Prefabricated internal walls accelerate construction timelines.

Numerous owners of large-scale commercial and industrial projects are reaping the rewards of quicker construction schedules by utilizing sandwich panel wall systems. These lightweight, prefabricated panels can be conveniently transported to the site and swiftly assembled, enabling other trades to commence their tasks without delay. In facilities like data centers, where maximizing uptime is crucial, these expedited construction techniques are enhancing and expediting the return on investment for their construction projects.

Paroc Panel System fire proof panels are prefabricated stone wool based lightweight sandwich panels. The facings are made of steel sheet and they act together with the PAROC structural wool core to provide a composite action of high performance in strength and durability. The bonding between the core and the facings is performed by an adhesive which fully covers the surfaces.

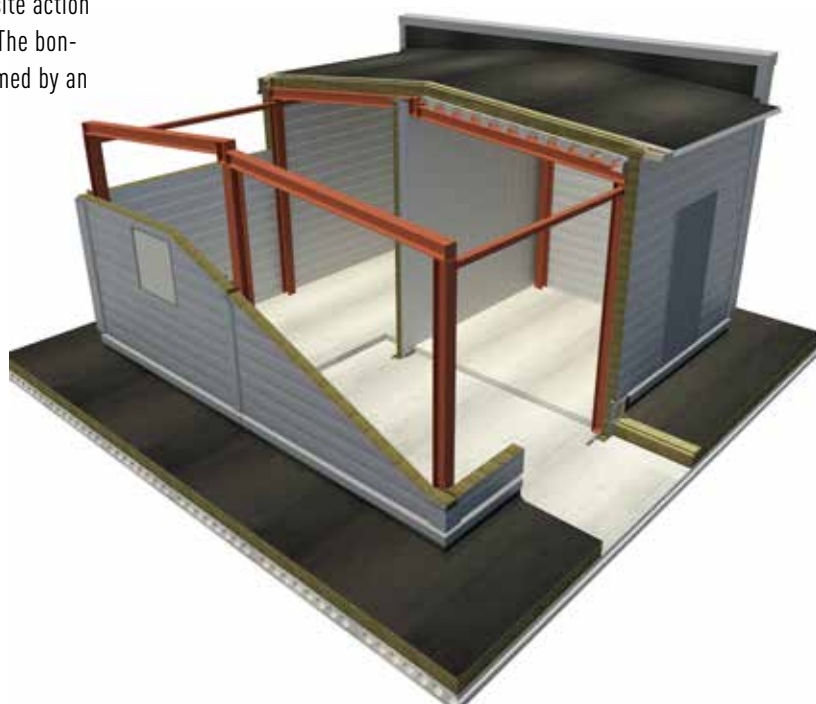

The test has been executed under the inspection of RISE in Borås, Sweden. The results from these tests (test report number 1186081 & 1186081-2) is the basis of the information presented. Recommendation for use of our products are based on tests and information that we consider to be correct. FireSeal AB is not responsible for results where the products are used outside our control. Specifications are subject to change without notice.

Prerequisites and requirements can vary, and thus the information in this brochure should be seen as a guideline, as in every project or design you need to consider the specific requirements and conditions the installation entails.

These requirements are the responsibility of the customer to handle, or an expert commissioned by the customer considering the actual project-specific design criteria and requirements. The tested wall thickness represents a minimum thickness required for the penetration fire-resistance rating.

RISE

POTENTIAL CHALLENGES

The current standards for testing fire penetration seals in sandwich panels have posed significant challenges for designers seeking effective solutions for these wall systems. Firestop manufacturers face difficulties in comparing results across different panel types and brands, which renders extensive testing prohibitively expensive. Consequently, there is a pervasive lack of tested systems available for these types of wall constructions within the industry.

Panel type	Panel property									
	Nominal thickness, mm	50	80	100	120	150	175	200	240	300
	Actual thickness, mm	53	79	99	120	151	173	202	243	305
AST* L	U-value, W/m ² K ¹⁾	–	0.45	0.37	0.30	0.24	0.21	0.18	0.15	0.12
	Fire rating, max ²⁾ horizontal/vertical	–	NPD	NPD	NPD	EI 120/ EI 180	EI 120/ EI 180	EI 120/ EI 180	EI 120/ EI 180	EI 120/ EI 180
	Weight, kg/m ² ³⁾	–	15	17	18	21	22	24	27	31
AST* S	U-value, W/m ² K ¹⁾	–	0.48	0.38	0.32	0.26	0.22	0.19	0.16	0.13
	Fire rating, max ²⁾ horizontal/vertical	–	EI 15/ EI 45	EI 60/ EI 60	EI 180/ EI 90	EI 180/ EI 120	EI 180/ EI 180	EI 180/ EI 240	EI 180/ EI 240	EI 180/ EI 240
	Weight, kg/m ² ³⁾	–	17	19	21	23	25	28	32	37
AST* S+	U-value, W/m ² K	–	–	0.38	0.32	0.26	0.22	0.19	0.16	0.13
	Fire rating, max ²⁾ horizontal/vertical	–	–	-/ EI 120	-/ EI 120	–	–	–	–	–
	Weight, kg/m ² ³⁾	–	–	19	21	–	–	–	–	–
AST* F	U-value, W/m ² K ¹⁾	–	0.53	0.43	0.36	0.29	0.25	0.22	0.18	0.14
	Fire rating, max ²⁾ horizontal/vertical	–	-/ EI 90	EI 45/ EI 120	EI 180/ EI 120	EI 240/ EI 180	EI 240/ EI 240	EI 240/ EI 240	EI 240/ EI 240	EI 240/ EI 240
	Weight, kg/m ² ³⁾	–	19	21	24	27	30	33	38	45
AST* F+	U-value, W/m ² K ¹⁾	–	–	0.43	0.36	–	–	–	–	–
	Fire rating, max ²⁾ horizontal/vertical	–	–	EI 120/ EI 120	EI 120/ EI 120	–	–	–	–	–
	Weight, kg/m ² ³⁾	–	–	21	24	–	–	–	–	–
AST* E	U-value, W/m ² K ¹⁾	0.77	0.53	0.43	0.36	0.29	0.25	0.22	0.18	0.14
	Fire rating, max ²⁾ horizontal/vertical	-/ EI 30	EI 15/ EI 45	EI 60/ EI 60	EI 180/ EI 90	EI 180/ EI 120	EI 180/ EI 180	EI 180/ EI 240	EI 180/ EI 240	EI 180/ EI 240
	Weight, kg/m ² ³⁾	16	19	22	24	28	31	34	39	47

NPD = No performance determined (not tested), – = Not available

¹⁾ U-values including surface resistance $R_{si} + R_{se} = 0.17 \text{ m}^2 \text{K/W}$ and the influence of joints. See also section 1.6.

²⁾ Maximum fire resistance depending on span. See details in the relevant classification reports and/or in technical documentation available on request.

Note that Paroc Panel System panels AST-E, AST-F, AST-F+, AST-L, AST-S, AST-S+ are classified in Euroclass A2-s1,d0, Acoustic Panels are classified in B-s1,d0 and Paroc PRINT and ART in C-s1,d0.

³⁾ Panels with standard facings.

Weighted sound reduction index RW is 28...3 dB.

Maximum panel length is 12 m but may be limited depending on panel thickness and type to ensure safe handling.

Module width is 1200 mm and cover width 1196 mm.

Tolerances are as follows:

- panel length ± 5 mm
- panel thickness ± 1 mm
- cover width ± 2 mm

FIRE SAFE SOLUTIONS

General

Paroc Panel System panels are classified in, Euroclass A2-s1,d0 in accordance with the standard EN 13501-1 (Paroc Panel System Acoustic Panels are classified in Euroclass B-s1,d0 and Euroclass C-s1,d0). Product technical specifications relating to fire classification are available from Paroc Panel System Technical Support. FM Approved product specifications are available in the FM Approval Guide: www.approvalguide.com

Figures: Behaviour of Paroc PS sandwich panels in case of fire.



Before fire the floor will carry the dead load of the panel.



Panel bows towards fire; the floor will still carry the dead load of the panel.



Most of the flexural strength of the panel is lost when the bond between exposed face and core fails. Panel dead load is then carried by suspension cleats.



The cold side of the panel bows outwards away from fire when temperature rises and the external steel sheet expands. Panel dead load suspended by cleats.

APERTURE FRAMING

Aperture framing

All rectangular openings must be framed on both sides of the wall with 30 x 30-L angles, fixed to panel facing with self-drilling screws at distances of 125 mm. Seal behind L-angles with Hilti CFS-S ACR acrylic sealant.

Openings and cut-outs

When dimensioning Paroc Panel System, account for strength loss that occurs due to openings and cut-outs for doors, windows, pipe penetrations, etc. Design panels with cut-outs to take the loads they are subject to irrespective of the openings. If this is not possible, loads directed on the panels are to be transferred to adjacent panels or using auxiliary structures to the building frame.

In case of large openings, the structures can be made of steel profiles transferring the load to the building main frame. The maximum opening sizes for single service penetrations do not reduce the strength of Paroc Panel System sufficiently to require special measures. However, multiple cut-outs within a panel must be considered cumulatively. If required, panels with higher strength classes may need to be used at openings. If the degree of cut-out exceeds the ratio q/q_{all} , the load is either to be transferred to adjacent panels in accordance with figure 2, or, if this is not possible, to be directed on the load-bearing frame by auxiliary structures. Consider maximum opening sizes noted on typical details in this brochure to remain within tested system parameters.

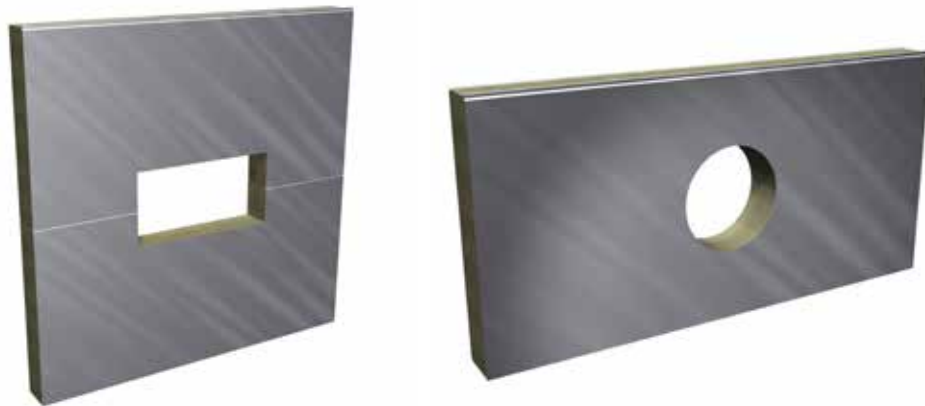

If the degree of cut-out exceeds the ratio q/q_{all} , the load is either to be transferred to adjacent panels in accordance with figure 14 or, if this is not possible, to be directed on the loadbearing frame by auxiliary structures. See also dimensioning example in the following section.

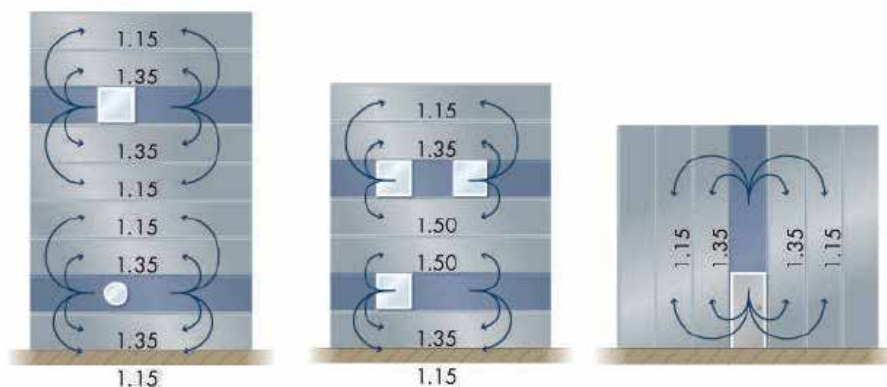

STRENGTH

Paroc Panel System masters the sandwich panel technology. Sandwich panels are based on interaction between the optimal strength properties. That is why the bonding between the core and the facings are the most critical part in a sandwich panel. In the panels the fully bonded facings together with the lamella orientation and pattern guarantee equal strength properties in each cross section. Paroc Panel System panels are specially developed to fulfil the high strength demands of load-bearing sandwich panels.

To guarantee reliable and uniform strength of a sandwich panel, the tensile strength of the bonding between the face and the core shall always exceed the tensile strength of the core material itself i.e. in the tensile strength test the failure always has to occur in the core. The tensile strength threshold value for AST® quality panels is 100 kN/m².

FIRE SAFETY

Paroc Panel System AST panels have been classified in Euroclass A2-s1,d0 which means that they are characterized by high fire resistance and they generate very little smoke and toxic products (s1) and do not form flaming molten droplets (d0). The fire resistance of Paroc Panel System structures is classified up to EI 240 as walls and EI 180 as ceilings.

The structural stone wool core has good thermal insulation also at extreme temperatures and it will not shrink. Shrinkage could cause loss of both insulation and integrity. The specially developed adhesive for Paroc Panel System panels has high temperature resistance keeping the core bonded to the unexposed face during a fire. Extra fixings in the joint prevent the penetration of hot gases and flames.

In case of fire, Paroc Panel System panels function as a catenary structure. Therefore, when designing fire-resistant structures it is important to execute the detail solutions so that the whole structure meets the requirements on stability, insulation and integrity.

DURABILITY

Durability in sandwich panels means long-term performance as a structural building component. Cladding products have to maintain their strength and insulating properties, and remain weather resistant over their entire service life. For industrial buildings, a lifetime of 25 years is often sufficient. In other cases, requirements can be 50 years or more.

AST® insulated panels use various primer and coating layers of steel sheets to eliminate the potential risk of corrosion inside the panel and ensure the bonding between the adhesive and the steel sheet. To secure colour and gloss retention in the panel surface, PVDF and spectrum are the standard coatings in external use. The adhesive fulfils high durability demands in all environmental conditions during the lifetime of a building. PAROC structural stone wool is water-repellent, non-hygroscopic and non-capillary, meaning no water can penetrate it. In addition, moisture has no effect on the stability of the core and the binder.

FIRE RESISTANCE CLASSES EI 30 – EI 180

Fire resistance of building elements and constructions can be classified into different fire resistance classes or combinations thereof. The different classes specify the different types of functional requirements. The class code usually also indicates a number which shows the time when the functional requirements are met in a standardised test. Source: Ri.SE Several classes than those given below are available, but are not relevant for the FireSeal range.

E Integrity (tightness)

Integrity E is the ability of a building element, with a separating function, to withstand fire on one side, and avoid it from spreading to the unexposed side through leakage of flames or hot gases. # When assessing the integrity of the component, we need to adhere to the following parameters:

- cracks or openings over a certain dimension
- ignition of a piece of cotton wool
- steady flames on the unexposed side of fire

Source: Ri.SE

I Insulation

Insulation I is the ability of a building element to, in the event of fire on one side, contain the temperature below a certain level on the unexposed side. Generally, the maximum temperature rise in an individual point should not be more than 180°C., and an average temperature rise on some points should not be more than 140°C..

Source: Ri.SE



SYMBOL DESCRIPTION



Water resistance

The product is water-repellent and therefore can be applied in aggressive environments e.g. outdoors.



Paintable

Painting should be done after the product is installed. The result may vary depending on the colour type.



Acoustic

The product has documented acoustic properties



Intumescent

In connection with fire and heat development, the entire or parts of the product swell and expand.



Elastic

The product is elastic, which makes it suitable for installations involving vibrations

SYSTEM FLEX C

FLEX BOARD SYSTEM

EI 120



Flex board is a system for larger penetrations in tougher environments, as industries, car washes and more, where you have a lot of empty space in the application. The system contains of 50mm thick stonewool slabs with a silicone layer. The system is approved for penetrations of cables and steelpipes. All gaps, around edges, cables and pipes should be sealed with Flex Sealant.



CABLE PENETRATION

Cabletypes, max diameter on cables/ boundled cables	Wall	Firerate
Small sheathed cables Ø 21mm	120	EI 60
Cables C1, C2 and C3	120	EI 60
Cables D1, D2 and D3	120	EI 60
Boundled cables max. Ø 100 mm, individual cable Ø 21mm	120	EI 60
Cableladder	120	EI 60

STEEL PIPE PENETRATION

Type of, with or without isolation and max pipe diameter	Wall	Firerate
Steel pipe without isolation Ø15mm	120	EI 90
Steel pipe without isolation Ø33,7mm	120	EI 60
Steel pipe, 50 mm Rockwool 80 isolation, 600 mm on both sides. Ø 60,3 mm - Ø 273	120	EI 90

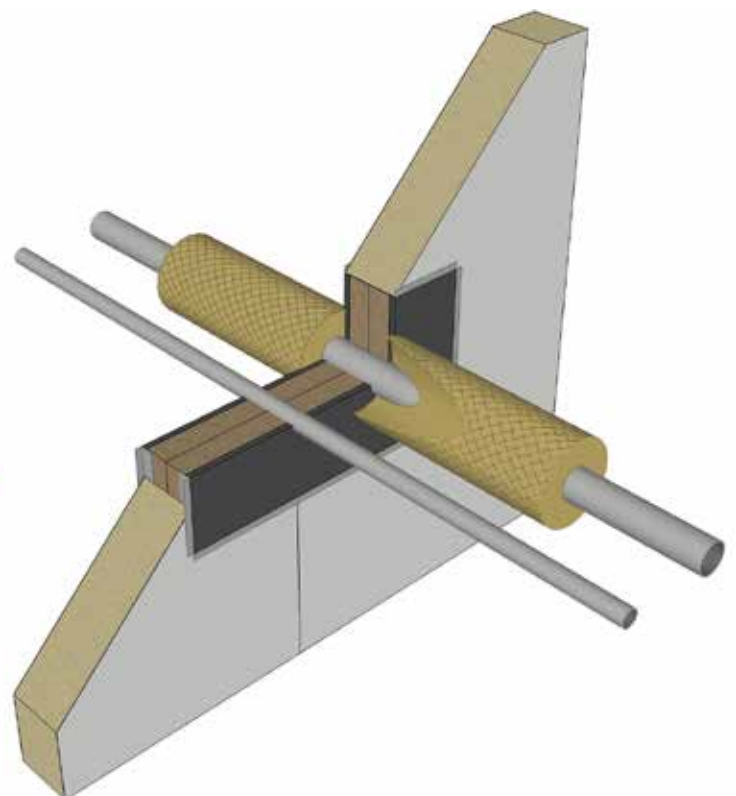
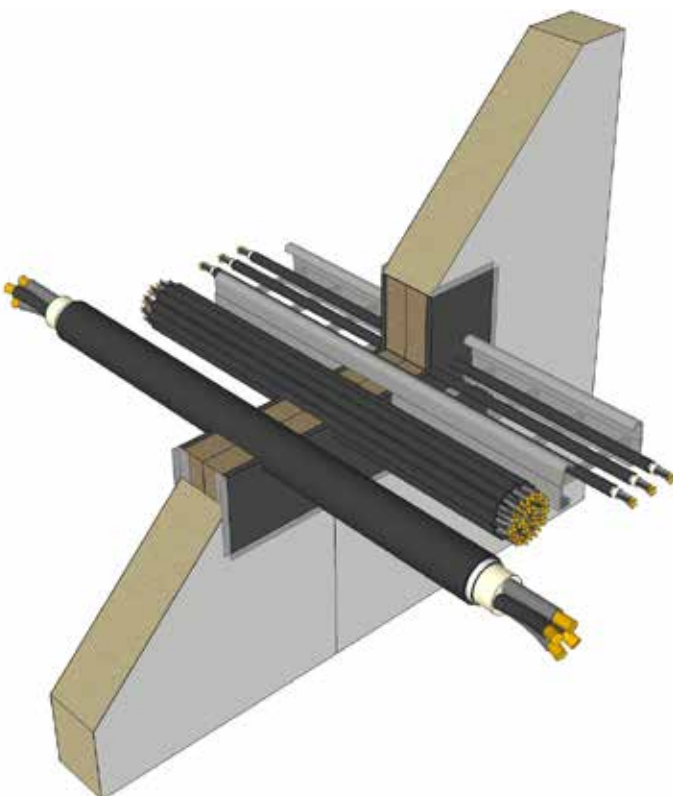

SYSTEM FLEX D

FLEX BLANKET SYSTEM

EI 180



Flex Blanket System is a flexible sealant system for sealing and repair of small and medium-sized openings for cables, metal pipes and for ventilation ducts. The system contains of a mineral wool and a silicone sealant that is mostly sealed on one side only.



CABLE PENETRATION

Cable types, max diameter on cables/ boudled cables	Wall	Firerate
Medium sheathed cables Ø50mm (C1, C2 and C3)	108+12	EI 60
Cables D1 and D2	108+12	EI 60
Boudled cables max. Ø 100 mm, individual cable Ø 21mm	108+12	EI 60
Cableladder	108+12	EI 60

STEEL PIPE PENETRATION

Type of, with or without isolation and max pipe diameter	Wall	Firerate
Steel pipe without isolation Ø15mm	120	EI 90
Steel pipe, Ø 60,3 mm - Ø 273, with Isolation (≥ 80 kg/m ³) with length 1000 mm on both sides.	120	EI 60
Steelpipe, 50 mm Rockwool 80 isolation, 600 mm on both sides. Ø 60,3 mm - Ø 273	120	EI 90

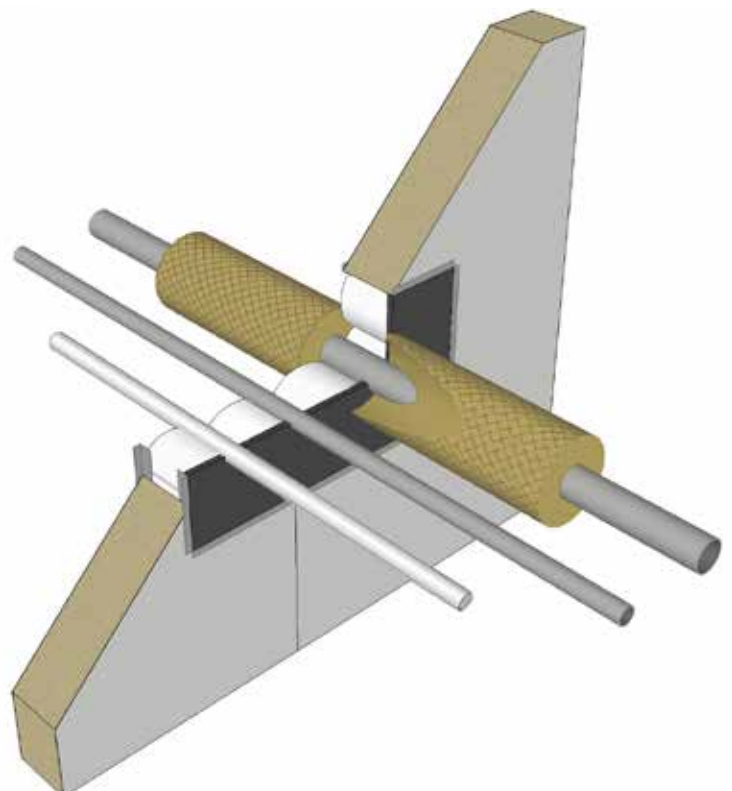
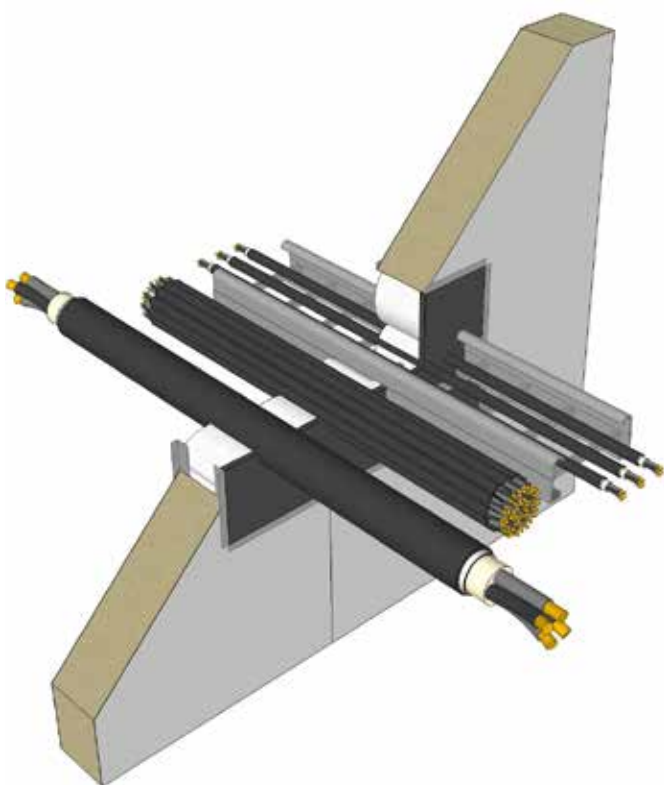

SYSTEM UNIVERSAL

EI 180

REACTIVE BOARD SYSTEM

Reactive board is a system for larger penetrations, where you have a lot of empty space in the application. The system contains of 60mm thick stonewool slabs with heat resistance layer. The system is aimed for penetrations of cables, steel pipes ventilation and plastic pipes $\leq \varnothing 110\text{mm}$ installed together with Maxi Wrap. All gaps, around the edges, cables and pipes should be sealed with Reactive or Flex Sealant.



CABLE PENETRATION

Cabletypes, max diameter on cables/ boundled cables	Wall	Firerate
Large sheathed cables $\varnothing 80\text{ mm}$	120	EI 90
Boundled cables max. $\varnothing 100\text{ mm}$, individual cable $\varnothing 21\text{mm}$	120	EI 90
Cableladder	120	EI 90

VENTILATION APPLICATION, max. hole measures 1000x800mm

Conditions	Wall	Firerate
The ventilation duct is insulated with mineral wool ($\geq 100\text{ kg/m}^3$, 80 mm thick). 1500 mm on each side. Continuous insulation is accepted	120	EI 60

PIPE PENETRATION

Type of, with or without isolation and max pipe diameter	Wall	Firerate
Steel pipe without isolation $\varnothing 33,7\text{mm}$	120	EI 60
Steel pipe 50 mm Rockwool 80 isolation, 600 mm on both sides. $\varnothing 60,3\text{ mm} - \varnothing 273$	120	EI 90
Steel pipe, 50 mm Rockwool 80 isolation, 600 mm on both sides. $\varnothing 60,3\text{ mm} - \varnothing 273$	120	EI 90
Plastic pipe $\leq \varnothing 110\text{mm}$ Reactive Board + Maxi Wrap (according to instructions for Maxi Wrap) on both sides of the application + Reactive Board.	120	EI 60

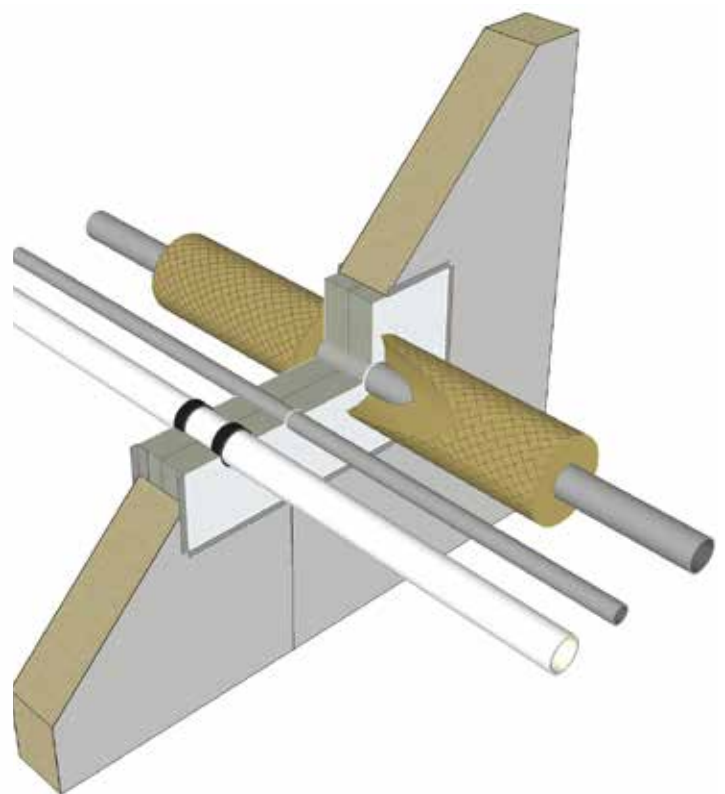
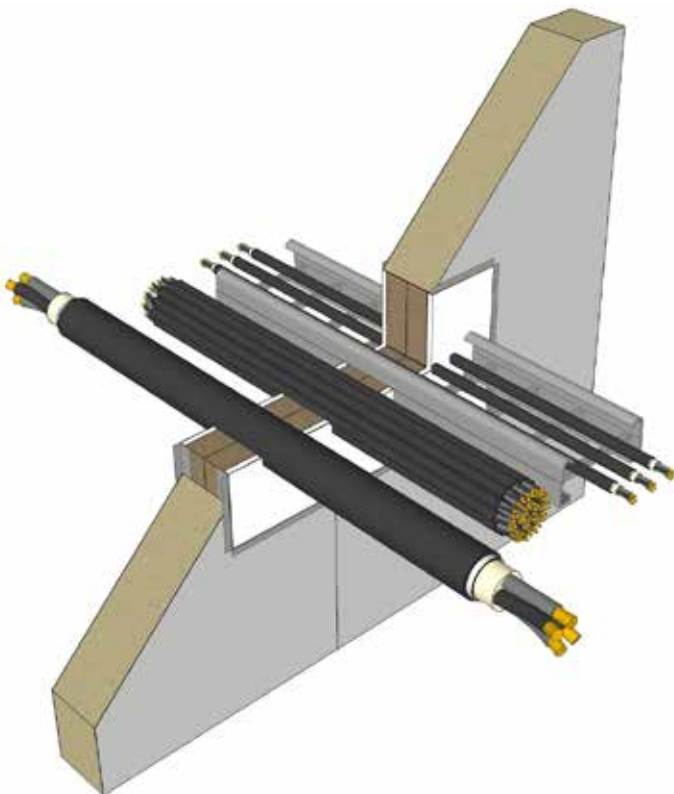

SYSTEM FLEX D

EI 180



REACTIVE BLANKET SYSTEM



Reactive Blanket System is a flexible sealant system for sealing and repair of small and medium-sized openings for cables, metal pipes, plastic pipes and ventilation ducts. The system contains of a mineral wool and an acrylic sealant that is mostly sealed on one side only.



CABLE PENETRATION

Cabletypes, max diameter on cables/bounded cables	Wall	Firerate
Large sheathed cables ≤Ø80 mm	108+12	EI 90
Bounded cables max. Ø 100 mm, individual cable Ø 21mm	108+12	EI 90
Cableladder	108+12	EI 90

ALUPEX PENETRATION

ALUPEX	Wall	Firerate
16 mm	108+12	EI 90
32 mm	108+12	EI 90

STEEL PIPE PENETRATION

Type of, with or without isolation and max pipe diameter	Wall	Firerate
Steel pipe without isolation Ø15mm	120	EI 90
Steel pipe, Ø 60,3 mm - Ø 273, with Isolation (≥ 80 kg/m3) with length 1000 mm on both sides.	120	EI 60
Steel pipe, 50 mm Rockwool 80 isolation, 600 mm on both sides. Ø 60,3 mm - Ø 273	120	EI 90

VENTILATION APPLICATION, max. hole measures Ø400mm

Conditions	Wall	Firerate
Ventilation duct is insulated with mineral wool (≥ 100 kg/m3 100 mm thick). 600mm on each side.	Sealant 12mm + min. 96mm Blanket	EI 60

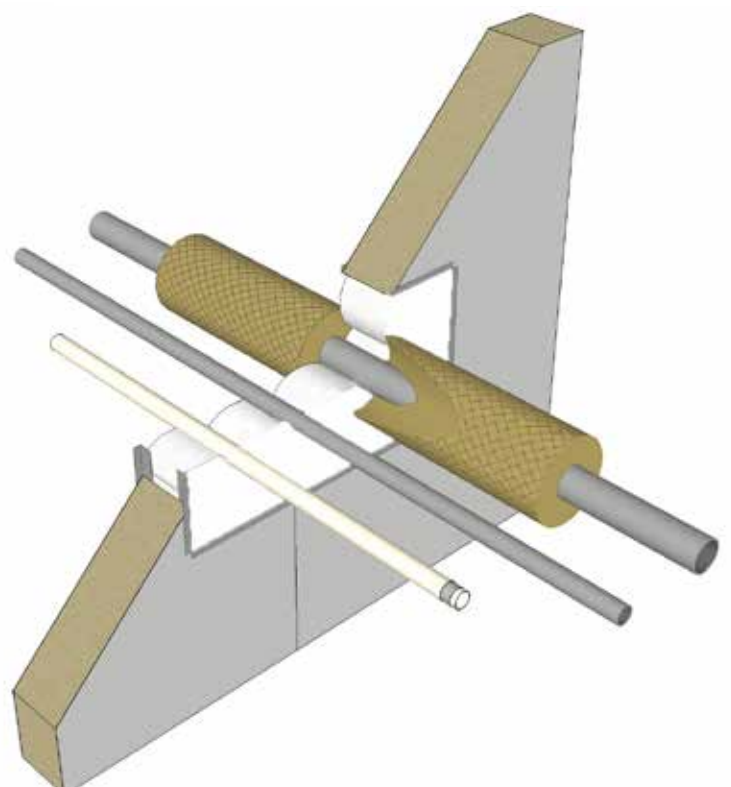
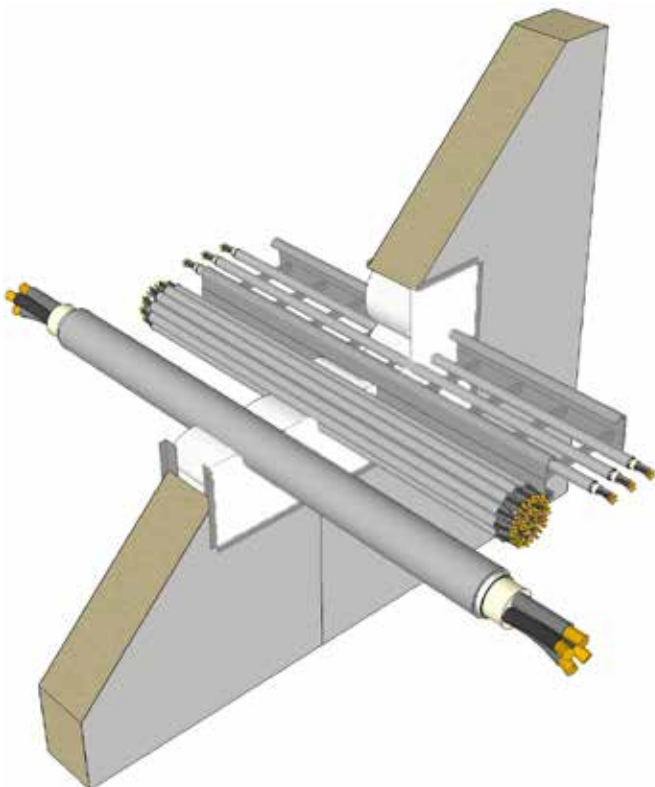

EI 180

FIRE BOX



Fire box is intended for applications with cables and metal- and plastic pipes. When heated, e.g. the effect of fire the internal graphite coating will effectively seal against the penetration of fire, gas and smoke. The Fire Box consists of a thin-walled steel material and contains an intumescent graphite material and a smoke/gas seal. The Fire Box is openable to provide an easy alternative to "retro-fit" there cables or pipes are pre-installed. When the box is assembled, nothing is required additional maintenance. During installation, a metal frame is used to hold the box in place, a frame mounted from each side. To ensure tightness, prevent flue gases the gap between box and wall/floor is sealed with Reactive [FS400] acrylic compound.



CABLE PENETRATION, Cables fitted through single Fire Box of dimensions, 250 x 125mm to 450 x 125mm

Service	Isolation	Firerate
Single or bundled cables $\leq \varnothing 80\text{mm}$	300 mm long insulwrap to services, 5 mm thick	EI 60
Up to 21 mm diameter telecoms , single or in bundles up to 100 mm diameter	No	EI 60
Unsheathed wire up to 24 mm diameter	300 mm long insulwrap to services, 5 mm thick	EI 60
Single or bundled cables, type A1, A2, A3 and C1	No	EI 60

CABLE PENETRATION, Cables fitted through single Fire Box of dimensions 102 x 102mm

Service	Isolation	Firerate
Telecom cables, single max. $\varnothing 21\text{ mm}$, bundled max $\varnothing 100\text{mm}$	No	EI 60
Single or bundled cables $\leq \varnothing 80\text{mm}$	300 mm long insulwrap to services, 5 mm thick	EI 60
Unsheathed wire up to 24 mm diameter	300 mm long insulwrap to services, 5 mm thick	EI 60
Single or bundled cables, type C2, C3, D1, D2 and E	300 mm long insulwrap to services, 5 mm thick	EI 60

PLASTIC PIPE APPLICATIONS, Pipe fitted through single Fire Box of dimensions 102 x 102mm

Service	Isolation	Firerate
PVC pipe $\leq \varnothing 82\text{mm}$ x 3.2mm wall PVC Pipe to EN 1329-1, EN 1453-1 or EN 1452-1	No	EI 60

COPPER PIPE APPLICATIONS, Pipe fitted through single Fire Box of dimensions 102 x 102mm

Service	Isolation	Firerate
Copper pipe $\leq \varnothing 54$	Isolation	EI 60

STEEL PIPE PENETRATION, Pipe fitted through single Fire Box of dimensions, 250 x 125mm to 450 x 125mm

Service	Wall	Firerate
Steel pipes 10mm diameter/1.0-14.2mm wall	6 to 19 mm K-flex ST or Armaflex insulation (CS)	EI 60
Steel pipes 25mm diameter/1.2-14.2mm wall	9 to 25 mm K-flex ST or Armaflex insulation (CS)	EI 60
Steel pipes 25mm diameter/1.2-14.2 mm wall	25 mm K-flex ST or Armaflex insulation (CS)	EI 60
Steel pipes 25mm diameter/1.2-14.2 mm wall	13 to 25 mm K-flex ST or Armaflex insulation (CS)	EI 60
Steel pipes 40mm diameter/1.5-14.2mm wall	13 to 40 mm K-flex ST or Armaflex insulation (CS)	EI 60
Steel pipes 40mm diameter/1.5-14.2mm wall	25 to 40 mm K-flex ST or Armaflex insulation (CS)	EI 60
Steel pipes 63.5mm diameter/1.6-14.2mm wall	9 to 32 mm K-flex ST or Armaflex insulation (CS)	EI 60
Steel pipes 63.5mm diameter/1.6-14.2mm wall	13-32 mm K-flex ST or Armaflex insulation (CS)	EI 60
Steel pipes 63.5mm diameter/1.6-14.2mm wall	19-32 mm K-flex ST or Armaflex insulation (CS)	EI 60
Steel pipes 63.5mm diameter/1.6-14.2mm wall	32 mm K-flex ST or Armaflex insulation (CS)	EI 60
Steel pipes 88.9mm diameter/1.6-14.2mm wall	13 mm K-flex ST or Armaflex insulation (CS)	EI 60
Copper pipes 10mm diameter 1.2-14.2mm wall	6 mm K-flex ST or Armaflex insulation (CS)	EI 60
Copper pipes 28mm diameter/1.5-14.2mm wall	9 mm K-flex ST or Armaflex insulation (CS)	EI 60
Copper pipes 42mm diameter/1.5-14.2mm wall	13 to 40 mm K-flex ST or Armaflex insulation (CS)	EI 60
Copper pipes 42mm diameter/1.5-14.2mm wall	19 to 40 mm K-flex ST or Armaflex insulation (CS)	EI 60
Copper pipes 42mm diameter/1.5-14.2mm wall	32-40 mm K-flex ST or Armaflex insulation (CS)	EI 60

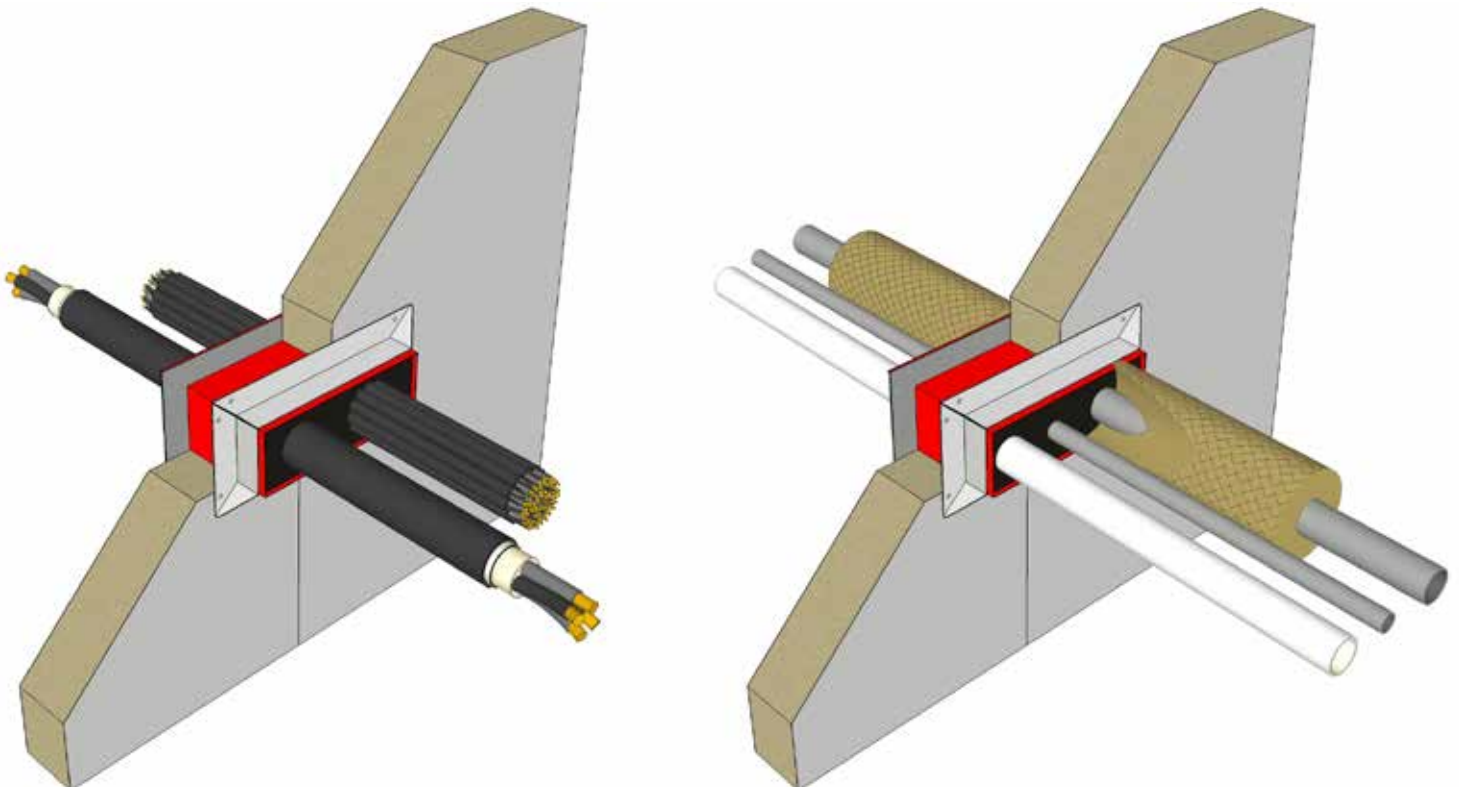

KNIPAREN

EI 180



KNIPAREN consists of a steel sleeve, internally coated with intumescent material, made for applications with plastic pipes and cables. In the case of a fire the coating will effectively seal the sleeve so no fire, gas or smoke will pass through. Cutting of the sleeve is not allowed due to the heat conditions during a possible fire. In preparation for future penetrations, it's possible to install additional empty KNIPAREN as long as the attached plastic lid is placed correctly to stop possible dangerous smoke in case of a fire.

PIPE PENETRATION

Type of pipe, and max dimensions (diamater and material thickness)	Ø KNIPAREN	Firerate
Without services	≤ Ø60	EI 60 - 90
PVC-pipe Ø10 mm x 1,5 mm	Ø16	EI 60 - 90
PE - pipe Ø50 x 5 mm	Ø16 - Ø60	EI 60 - 90
PP - pipe Ø40 mm x 1,8	Ø16 - Ø50	EI 60 - 90

CABLE PENETRATION

Type of cables	Ø KNIPAREN	Firerate
Cables A1, A2, A3, F	Ø16 - Ø50	EI 60 - 90
Cables A1, A2, A3, C1, C2, C3, F	Ø60	EI 60
Cables C3	Ø40 - Ø50	EI 60

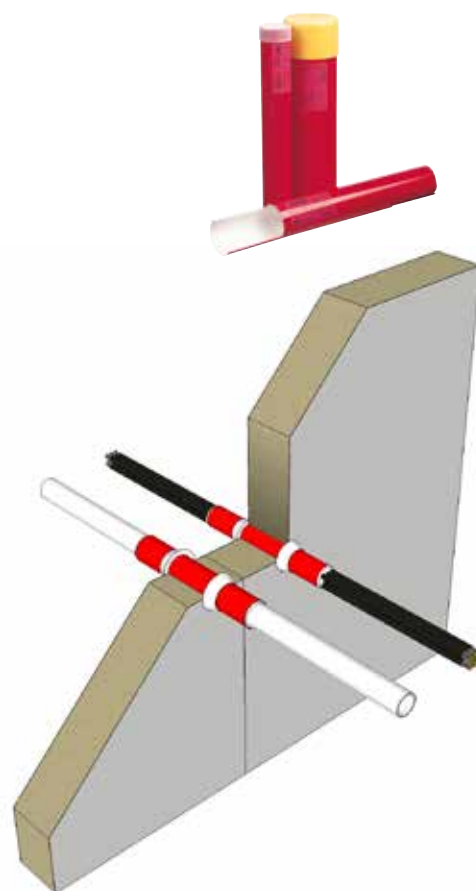

MAXI WRAP

EI 120



Maxi Wrap is a flexible intumescent tape, made for applications with plastic pipes made of PVC-U, PVC-C, PE-HD, PE, ABS, SAN+PVC, PP-R, that mainly consists of graphite. The band is cut to the desired length according to the below table and adjusted after installation. When the temperature rises above 140°C, the tape will intumescent and under high pressure effectively seals the collapsing plastic pipe. Pipes over Ø75 mm must have double seals, below Ø75 mm one seal is sufficient. The practical packaging means that the band is easy to adapt to different dimensions.

PIPE PENETRATION

Pipe diameter (mm)	Number of layers	Number of wraps	Total thickness of the wrap (mm)	Firerate
15 Ø ≤ Ø75	2	1	5	EI 60 - 120
Ø75 ≤ Ø90	2	2	5	EI 60 - 120
Ø110	4	2	10	EI 60 - 120

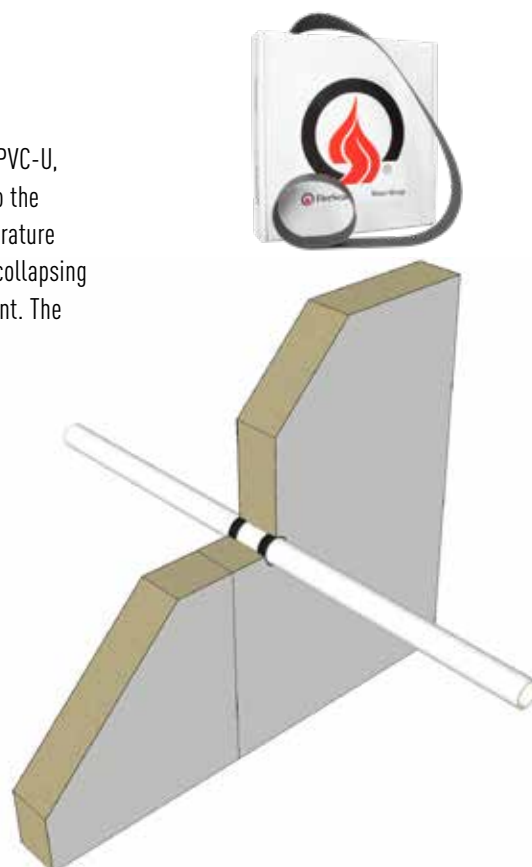

SQUEEZER COMPACT

EI 120



Squeezer Compact is easily mounted around plastic pipes for water and sewage as well as similar pipes that pass-through fire cell separating building parts. The plastic pipe clamp is made of a thin-walled galvanized steel sleeve with an internal swelling body of pressed graphite material. It is openable and is manufactured with a low construction height, which greatly simplifies assembly. In the event of a fire, the plastic pipe is sealed as the graphite expands and prevents the penetration of fire, smoke and gas. The clamp is attached to the wall or plane by screwing into the protruding steel brackets. The approval concerns pipes made of PVC-U, PVC-C, PE-HD, PE, ABS, SAN+PVC, PP-R.



SINGLE PLASTIC PIPE PENETRATION

Pipe materials	Pipe diameter (mm)	Wall	Intumescence width	Intumescence thickness	Fire rate
PVC-U /PVC - C	Ø≤32	1,8 - 3,4	30	5	EI 60 - 120
	32 < Ø ≤51	2,2 - 4,1	30	7,5	EI 60 - 120
	51 < Ø ≤71	2,5 - 4,9	30	10	EI 60 - 120
	71 < Ø ≤90	2,9 - 5,7	30	12,5	EI 60 - 120
	90 < Ø ≤110	3,2 - 6,5	30	15	EI 60 - 120
PP-R	Ø≤63	5,8	30	5	EI 60 - 120
	Ø≤63	5,9 - 7,9	30	7,5	EI 60 - 120
	63 < Ø ≤ 87	5,8 - 7,9	30	7,5	EI 60 - 120
	87 < Ø ≤ 111	5,8 - 10,1	30	10	EI 60 - 120
PE-HD	Ø≤63	3,0 - 5,8	30	5	EI 60 - 120
	63 ≤ 87	3,8 - 7,9	30	7,5	EI 60 - 120
	87 < Ø ≤ 111	4,6 - 10,1	30	10	EI 60 - 120
PVC-U/PVC-C	Ø≤63	2,0 - 5,1	30	5	EI 60 - 120
	63 ≤ 87	2,3 - 5	30	7,5	EI 60 - 120
	87 < Ø ≤ 111	2,6 - 4,9	30	10	EI 60 - 120

BUNDLED PLASTIC PIPE PENETRATION

Pipe materials	Pipe diameter (mm)	Wall	Intumescence width	Intumescence thickness	Fire rate
PP-R	Ø≤32	2,9 - 5,4	30	7,5	EI 60 - 120
	32 < Ø ≤40	3,5 - 5,4	30	10	EI 60 - 120
	40 < Ø ≤ 49	4,1 - 5,5	30	12,5	EI 60 - 120
	49 < Ø ≤ 57	4,6 - 5,6	30	15	EI 60 - 120
	57 < Ø ≤ 66	5,2 - 5,7	30	17,5	EI 60 - 120
	66 < Ø ≤ 75	5,8	30	20	EI 60 - 120

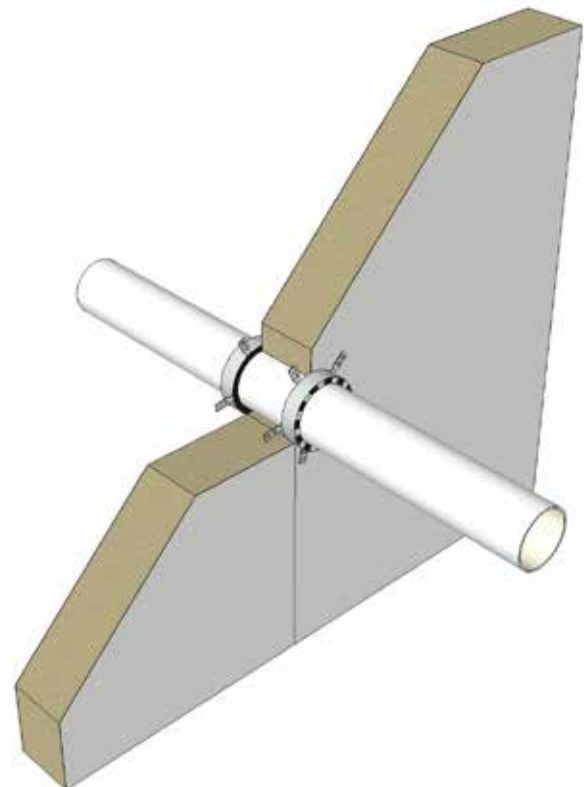



FireSeal AB
Esbogatan 14
SE-164 74 KISTA
SWEDEN
+46(0) 8 623 6160
info@fireseal.se
www.fireseal.se



FireSeal



The fireseal system originally developed to safeguard nuclear power plants